

Abstract

The decrease of physical activity in children has significant health consequences for society because it is directly linked to an increase of obesity in children and osteoporosis in adults. Research has shown that the intensity of weight-bearing activities is crucial in developing bone mass and strength. Last year's senior design team developed a Pediatric Step Monitor that measures the magnitude and duration of forces exerted on the soles of children's feet. However, the device had some limitations due to its bulkiness and the necessity to transmit data in real-time via a Bluetooth. The device designed this year is small enough to be embedded in a child's shoe and data is stored on board in a memory chip.

Authors

Michelle Kam, EE '06
Dong Tran, EE '06

Advisors

Dr. Jay N. Zemel
Dr. Babette Zemel

Demo Schedule

April 18, 2006
9:00 AM, 9:30AM, 10:30AM,
11:00 AM, RCA Lab

Department of Electrical
and Systems Engineering

System Design

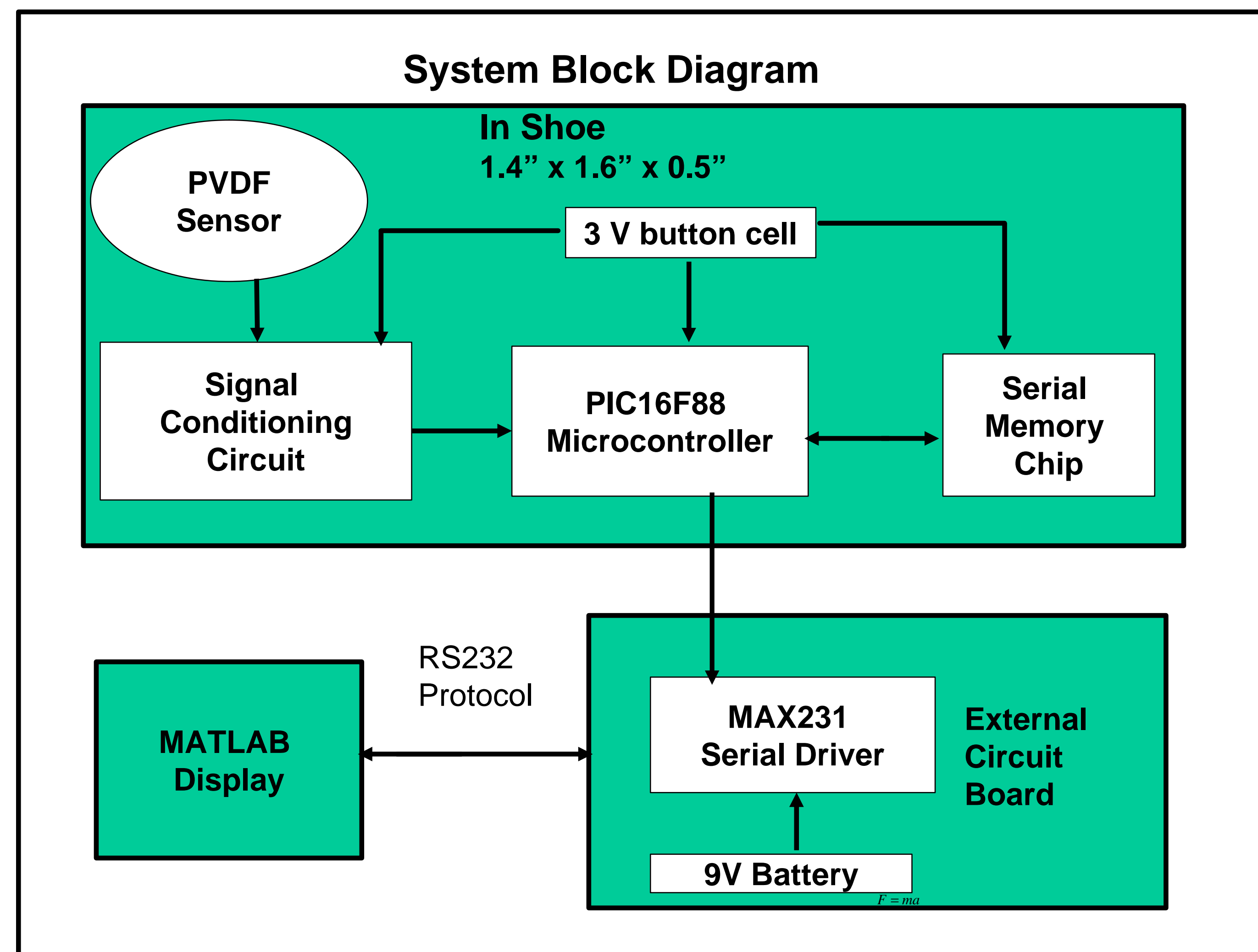

The Pediatric Dynamometer designed this year consists of a piezoelectric polyvinylidene fluoride (PVDF) sensor, a signal conditioning circuit, a microcontroller for data processing and a memory card for data storage. At the end of the day, the device which is embedded in the shoe will be removed and its data downloaded onto a computer to a simple graphical interface, displaying information such as force magnitude and energy expenditure..

PVDF Sensor Operation

The DT1-028K sensor used is a piezoelectric sensor. When the sensor is deformed as during a typical step, an external current proportional to dF/dt , or the time rate of change in force applied to it, is induced.

Force and kinetic energy information is obtained from the sensor output using the following equations:

$$F = \int_t \frac{dF}{dt} dt = ma = m \frac{dv}{dt}$$

$$\frac{dv}{dt} = \frac{1}{m} \int_t \frac{dF}{dt} dt \rightarrow v = \frac{1}{m} \int_t \int_t \frac{dF}{dt} dt dt$$

$$Kinetic\ Energy = \frac{1}{2} mv^2 = \frac{1}{2m} \left(\int_t \int_t \frac{dF}{dt} dt dt \right)^2$$

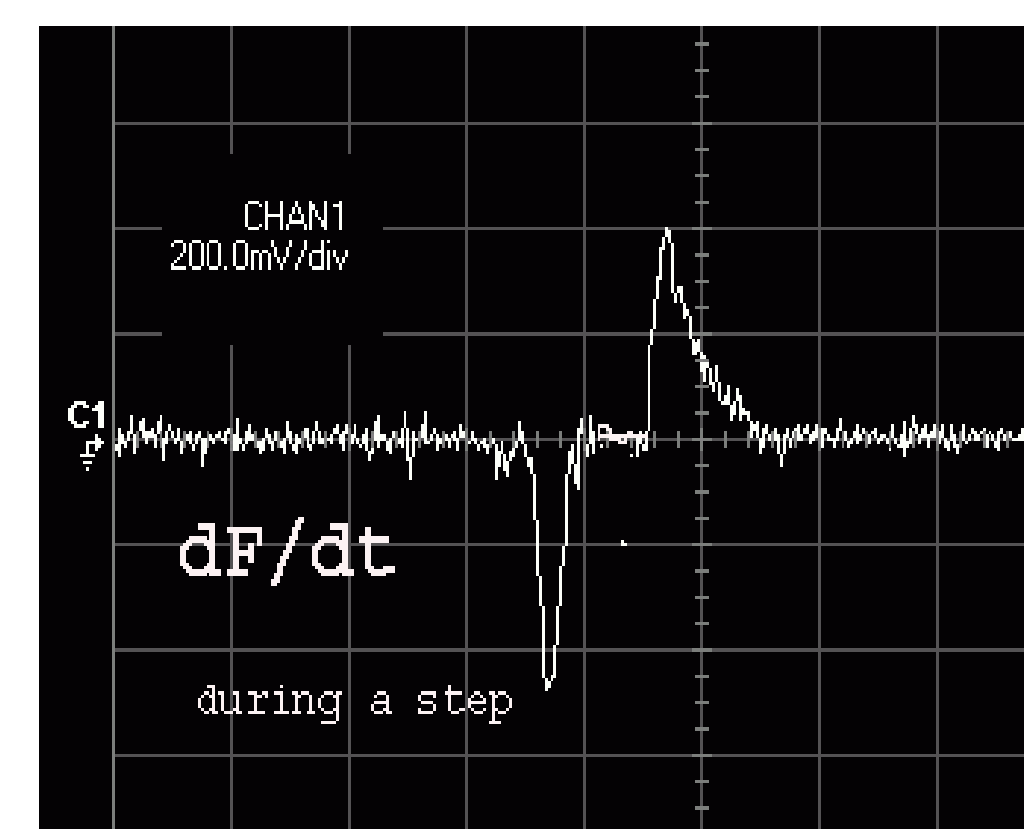

Signal Conditioning

A signal conditioning circuit consisting of an instrumentation amplifier (AD627) is needed between the sensor and the analog-digital converter (ADC) of the microcontroller. Its purpose is to:

- offset the bipolar signal from the PVDF sensor
- amplify the signal from the sensor to a 0 - 3V range
- transform the high input impedance from the sensor to a low output impedance for the ADC
- reject common-mode noise from the sensor

Accelerometer

An iMEMS accelerometer (ADXL204) was investigated as an alternative to the PVDF sensor. Acceleration data is recorded from the accelerometer. Force data can be obtained from the acceleration data using $F = ma$. A pendulum system was constructed to study its behavior.



Digital Subsystem

The digital subsystem consists of a microcontroller and a serial memory chip. The following functions are supported:

- Sample analog signal from the signal conditioning circuit at 200 samples/ sec.
- Integrate samples to obtain peak and average force of each footstep.
- Timestamp each set of force data.
- Store force data and timestamps in serial memory chip.
- Transfer data from memory chip to a computer via RS232 serial link

Packaging in Shoe

The PVDF sensor with a metal backing is attached to bottom of shoe insole.

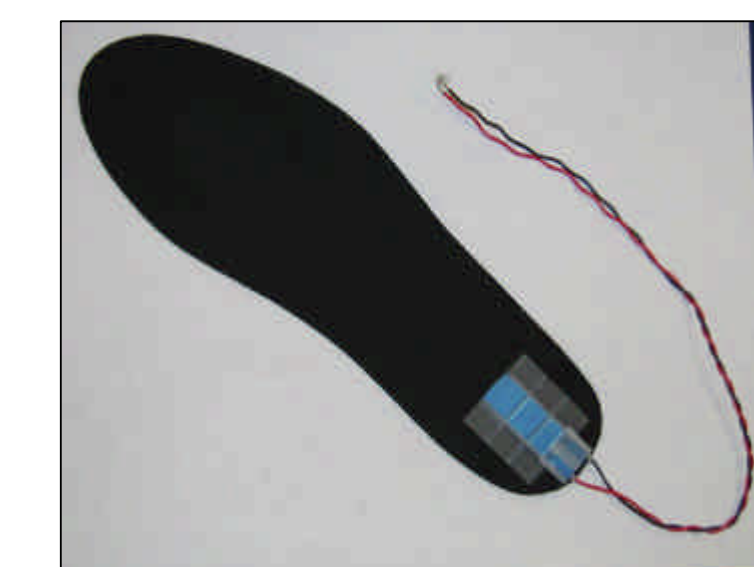

Printed circuit board and battery are inserted into the cavity of a child's shoe.